

Manual

V BOT

4K HDMI Loop Camera Motorized Head



Contents

Pre-Caution Before Operation	3
V BOT, 4K HDMI Loop Motorized Head	4
1, Introduction	5
2. Key Highlight	6
3. Technical Specification	7
4. Product Overview	8
4-1 Front	8
4-2 Rear	8
4-3 Product Blueprint	9
4-4 Components	10
5. Operation	11
5-1 LED Status	11
5-2 System Diagram	13
5-3 V BOT Controlling	14
5-4 System Diagram (con't)	15
6. Controlling	16
6-1 SHARON proSTICK Controller	16
White Balance & Auto Exposure Settings	17 - 20
7. Camera Remote Connectivity and HDMI workflow	22
8. VBOT Finder	
8-1 VBOT Finder Apps Download	23
8-2 VBOT Finder GUI	23
9. SONY Multiport Converter Module Option	24
9-1 List of Camera Models	24
9-2 List of SONY Camera supported by SONY MULTISUPPORT Interface shoe	25
Appendix—A. CANON COMMAND Key List	26 - 28
Appendix---B. VISCA COMMAND Key List	29 - 42

1. Precautions before installation

Describes basic precautions that users should be aware of when installing and using the product in case of a situation that may cause bodily harm. Therefore, before installing or using the product, be sure to familiarize yourself with the information described here.

General precautions

During and after installation of the product, the area around the product must be kept clean and dust-free.

Do not leave tools, cables, etc. in the aisle, as this may result in personal injury.

When installing the product, avoid wearing loose-fitting clothes, neckties, scarves, or sleeves that may get caught in the product.

Do not take any action that could cause damage to persons or equipment.

If you need to open the cover of the product to extend the product's performance or repair a malfunction, be sure to contact the place of purchase for professional help.

Power Precautions

When connecting power to the product, first check that the wiring is not overloaded.

When connecting the power to the product, do not wear jewelry such as rings, necklaces, or watches. If these accessories are connected to a power source or ground, there is a risk of burning the parts.

Always check the work area for potential hazards. Be sure to check for wet floors, ungrounded power extension cables, frayed internal power cords, and floors that do not have a safety grounding facility.

There must be an outlet near the appliance and the outlet must be easily accessible.

Install by service personnel and install the appliance so that it is connected to a socket-outlet with a protective earth wire



Before proceeding with hardware installation, turn off the power of the system to be installed, and then touch a grounded surface such as the metal side of the power supply to discharge static electricity from the body.

The manufacturer assumes no liability for direct or indirect damage resulting from the use of improper parts by unauthorized service personnel.

If power is supplied during installation, it may cause damage to system components and body.

Power

The power cord and power outlet act as the main power disconnect device in case of an emergency such as a fire, so do not stack or block objects in front of the power outlet so that you can unplug the power cord from the power outlet at any time.

FCC Compliance Statement



This device complies with part 15 of the FCC rules. Operation is subject to the following two conditions: (1) This device may not cause harmful interference, and (2) This device must accept any interference received, including interference that may cause undesired operation.



CE Marking is the symbol as shown on the left of this page. The letters "CE" are the abbreviation of French phrase "Conformité Européene" which literally means "European Conformity". The term initially used was "EC Mark" and it was officially replaced by "CE Marking" in the Directive 93/68/EEC in 1993. "CE Marking" is now used in all EU official documents.



Warranty

Standard 1 Year Warranty

- SalrayWorks product is guaranteed against any manufacturing defects for one year from the date of purchase.
- The original purchase invoice or other documentary evidence should be supplied at the time of any request for repair under warranty.
- The product warranty period begins on the purchase date. If the purchase date is unknown, the product warranty period begins on the thirtieth day after shipment from a SalrayWorks office.
- Damage caused by accident, misuse, unauthorized repairs, sand, grit or water is not covered under warranty.
- Viruses and malware infections on the computer systems are not covered under warranty.
- Any errors that are caused by unauthorized third-party software installations, which are not required by our computer systems, are not covered under warranty.
- All mail or transportation costs including insurance are at the expense of the owner.
- All other claims of any nature are not covered. All accessories including headphones, cables, batteries, metal parts, housing, cable reel and consumable parts are not covered under warranty.
- Warranty only valid in the country or region of purchase.
- Your statutory rights are not affected.

V BOT, 4K HDMI Loop Camera Motorized Head

Robotic Pan Tilt Head

1. Introduction

*Bring the remote-control functionality to your Hand-held camcorder with the **V BOT Robotic Pan Tilt Head** from **Salrayworks**. More than just a motorized head, V BOT interfaces with PTZ-compatible control systems, allowing you the same kind of experience. From pan and tilt control to powering your camera and controlling its zoom lens via LANC or other protocols, this head is a compact PTZ solution for cameras weighing up to 3.2Kg. The head easily mounts to most tripod legs and with an optional bracket, it can be mounted on a wall or ceiling. It can send your camera's video output to external video displays, switchers, and controllers while also receiving control information for pan and tilt operations via VISCA IP . The head is equipped with LED indicators, a tally light, and a remote port that allows you to adjust the zoom and focus of select camera lenses.*

- Multiple signal interfaces such as, HDMI, tally, and LANC / MULTI / CANON XC
- Sturdy aluminum construction
- Camera pan, tilt, and zoom control
- VISCA IP remote control
- Compatible with Salrayworks proStick Controller or 3rd party visca IP controller
- Built-in tally light
- Ideal for live events
- Control a variety of Sony, Panasonic, Canon, and JVC cameras
- Plate with ¼ thread for camera mounting
- HDMI2.0 Re-timer Buffer support
- Supports up to 4K60P resolution

2. Key Highlight

- Fitted with up to a 3.2 kg (70 lb) camera it moves up to 340 PAN degrees and TILT Down 35 degrees as well as 20 degrees UP at a rate of 15 degrees per second.
- This exquisitely designed V BOT is incredibly quiet and smooth in motion, so it won't interfere with in-studio shooting or your live Streaming.
- Power (PoE+) and Ethernet cable. The camera's zoom-in-out, focus and IRIS can be controlled remotely using the 2.5 mm LANC / MULTI / CANON XC
- It stores and recalls up to 10 positions with a precision less than 0.1 degrees. Whether at the studio or on the stage, memorizes the previous location with extreme accuracy and immediately begins shooting.
- All menus can be supported remotely by supporting cameras that support the CANON XC protocol

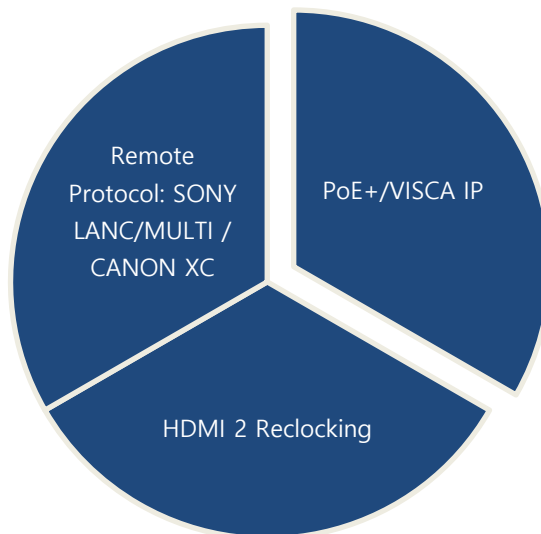

3. Technical Specification

	<ul style="list-style-type: none"> • Robotic Pan / Tilt Head
Input	<ul style="list-style-type: none"> • Supports Sony VISCA operation via Ethernet connection • POE+ (Power over Ethernet – 802.3at) support • HDMI 2.0 video/audio input
Pan	Turning radius 170 degrees to the right and 170 degrees to the left (340 degrees) ** 360 degrees possible when the sensor is off** Speed: 180 degrees in 10 seconds (Variable speed in 1~24 steps)
Tilt	Turning radius up 20 degrees down 35 degrees Speed: 15 degrees per second (Variable speed from 1 to 24 steps)
Preset	10 position Save Save Pan/Tilt Position Save , Speed Save Focus Zoom In/Out Position Save , Speed Save Pan/Tilt *4 (at CANON XC)
Ex-Control	1.LANC input Camera Remotely control Zoom In/Out (Speed 1~12 step), Focus 2. Sony Multi Control (option Cable Requires) 3. Canon XC Protocol Compatible.
Tally	Internal / external Tally support
Output	HDMI 2.0 video/audio output 4K resolution support Tally Light
Management	Front status LED support Support for remote firmware update
Physis	Dimension : 128(H) X 157(W) X 157(D) Operation Temperature : 0~45°C Weight : 1.87 Kg Power Consumption: Max 20W

Installation Precautions • It is recommended to install so that the height of the center of the housing at the top of the CAMERA MOUNT BASE is less than 50mm. Cause • Do not exceed the loading weight (3.2kg) of this PAN-TILT and install it so that the center of the housing member coincides with the center of this PAN-TILT. How to operate TILT (upper, lower) angle In the figure above, if you loosen two bolts in the part where the label is drawn, you can see two bolts in the half-moon-shaped groove. Loosen these two bolts 2-3 turns to adjust to the desired angle position, and tighten so that it does not loosen, the angle adjustment is successful. How to operate the PAN (left, right) angle SPT-510 There are two bolts on the top of the connector at the bottom of the outside. Loosen these two bolts 2-3 turns to adjust them to the desired angle and tighten them so that they do not loosen.

4. Product Overview

4.1. Part

4.1.1 Front

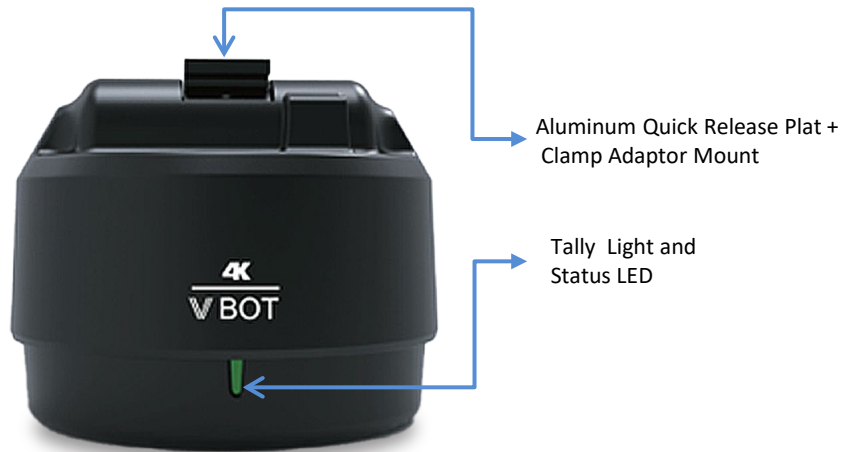

4.2. Rear

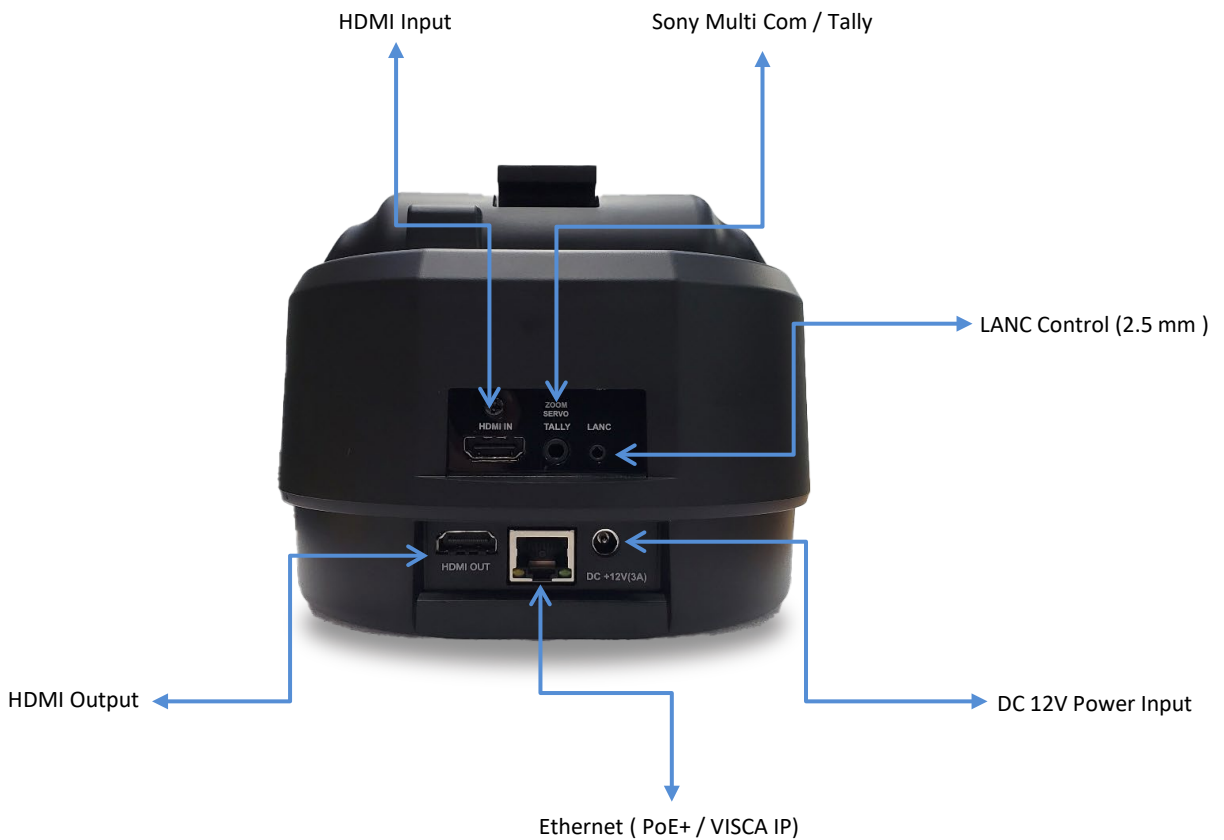

4.3 Product Blueprint

4.3.1 Front Size

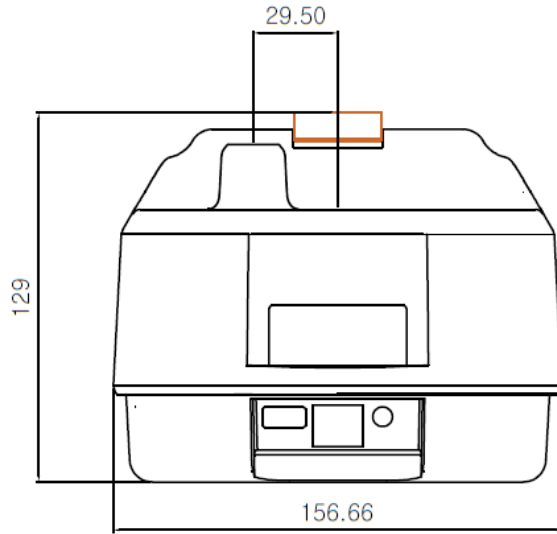

4.3.2 Top Size

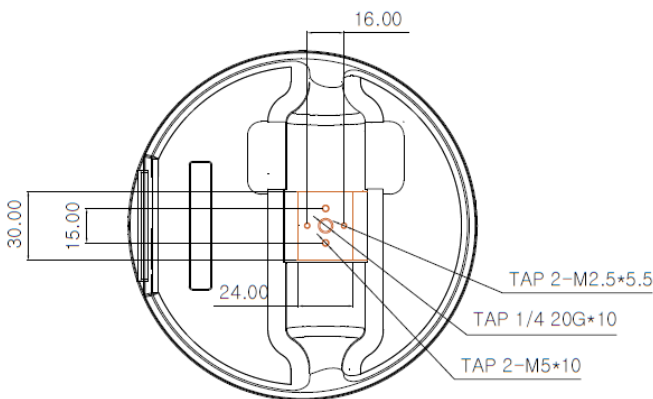

4.3.3 Bottom Size

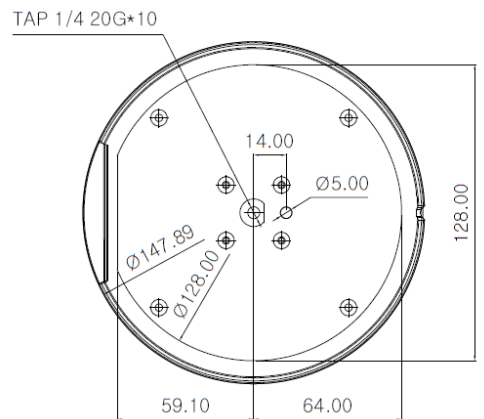

4.4 Components

This product consist of .

1. V BOT PAN TILT Head
2. DC Power : DC 12V 3A
3. Quick Release Clamp Adaptor
4. LANC Cable (2.5 π 3pol I)
5. Multiport Converter Cable (Option) Multi Protocol (3.5 π 4pol , Multiport)
6. Multiport LANC Cable (Option) L Protocol (2.5 π 3pol , Multiport)



1. . V BOT PAN TILT Head



2.DC power



3.Quick Release Clamp



4.LANC cable



5. SONY MUTICOM Cable for
SONY a7III / FX3(Option)

5. Operation

5.1. LED Status

The status LED has two colors, green and red, and the meaning of each color is as follows.



- Green blinking during booting
- Green blinks when command is received



- Red LED lights up when Tally On command
- Red LED turns off when Tally Off command

V BOT performs calibration by rotating Max 180 degrees at every boot.

"The red LED lights up in case of an initialization failure."

5.2. 2.5 mm LANC Camera System Diagram

As shown in the figure below, V BOT is easily connected to the legacy Internet network with a camera, IP switch, router and PC with a minimal cable Ethernet cable.

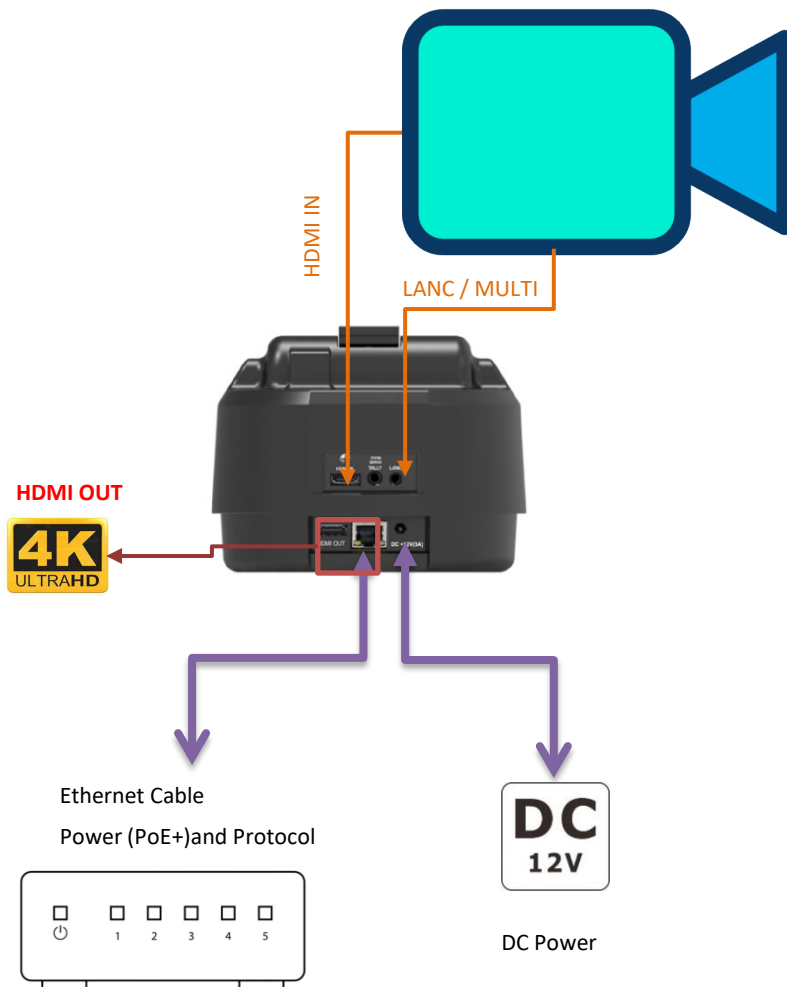

5.3. Canon XC Camera System Diagram

As shown in the figure below, V BOT is easily connected to the legacy Internet network with a camera, IP switch, router and PC with a minimal cable Ethernet cable.

Canon XC supported Camera Model : **XF605, EOS C300 Mark III, EOS C500 Mark II, EOS C70, C400**

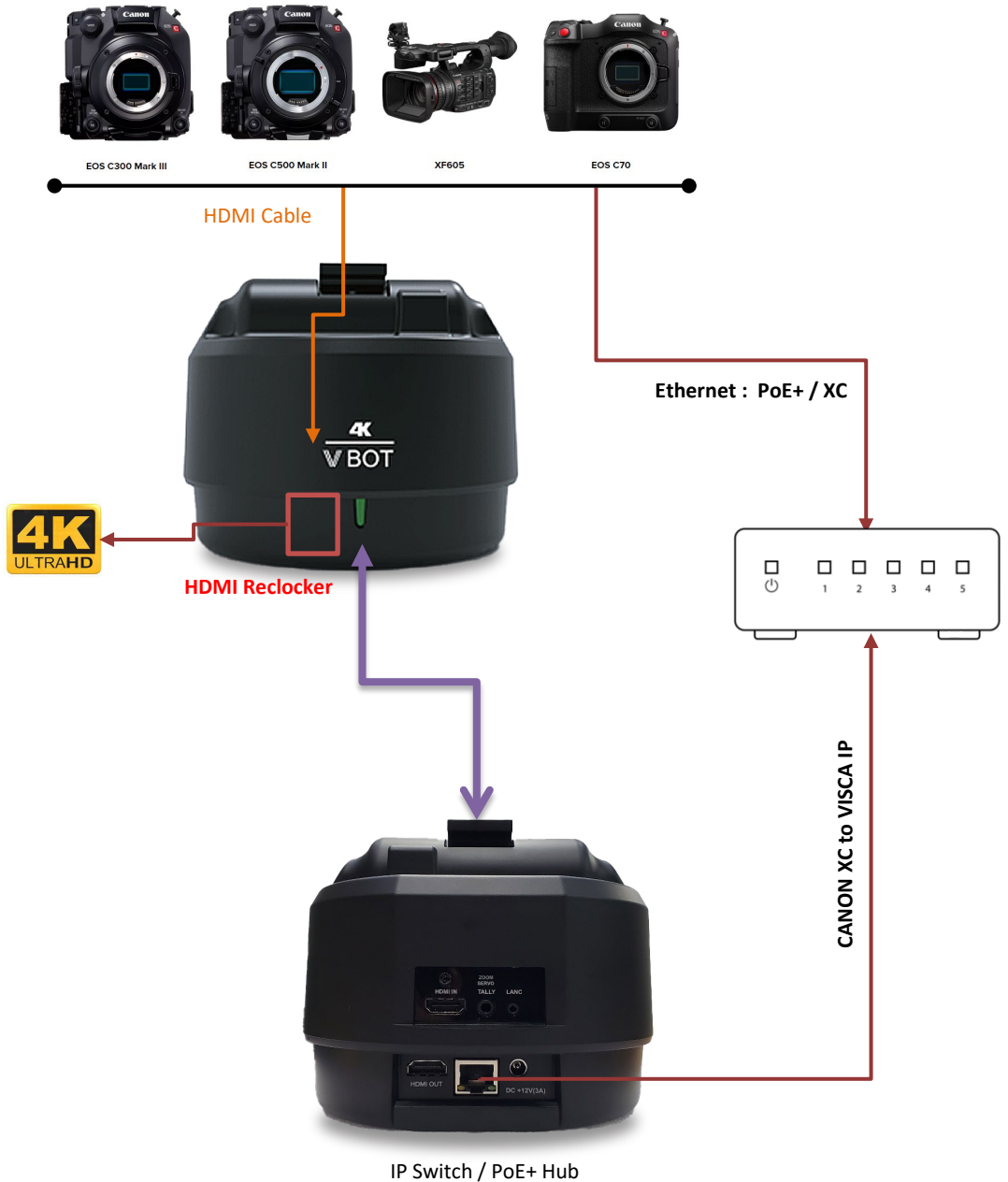

IP Switch / PoE+ Hub

5.3. SONY LANC / MULTI Camera System Diagram

As shown in the figure below, V BOT is easily connected to the legacy Internet network with a camera, IP switch, router and PC with a minimal cable Ethernet cable.

SONY MUTICOM Option requires Model : **SONY Alpha 7 III, SONY FX3**



VBOT
SONY FX3, Alpha7a



5.4. CANON XC Camera System Diagram



CANON XC Compatible

VBOT

Canon XC Case

- White Balance
- AE Gain
- ZOOM Position
- Focus Position
- AE Shutter
- AE IRIS Position
- AE Level
- Position
- WB Rgain
- WB Kelvin



6.1 Controlling – SHARON proSTICK Controller

- It is possible to operate and intuitive preset with fine movements through VISC IP with SHARON proSTICK Controller or 3rd party VISC IP Controller.
- Camera OSD, PAN TILT, Preset, can be controlled.



SHARON proSTICK Controller

6. 1 SHARON proSTICK Controller for CANON XC Mode

- It is possible to operate and intuitive preset with fine movements through VISC IP with SHARON proSTICK Controller or 3rd party VISC IP Controller.
- Camera OSD, PAN TILT, Preset, can be controlled.

White Balance

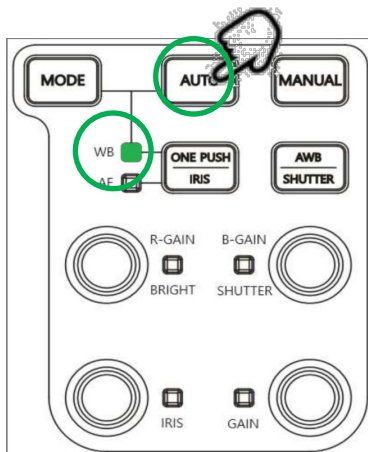

6. 1.1 WB Auto

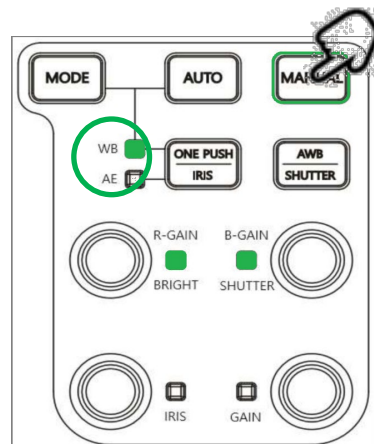

6. 1.2 WB Manual

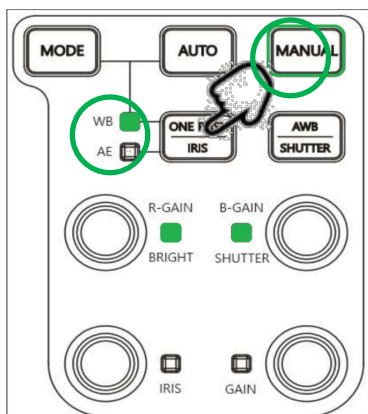

6. 1.3 AWB Hold Off

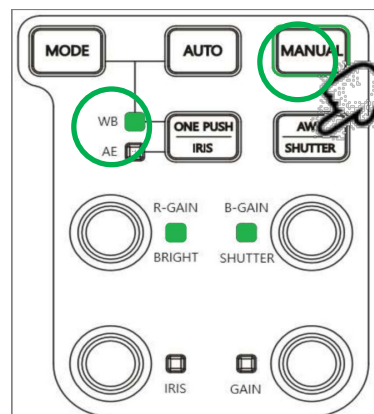

6. 1.4 AWB Hold On

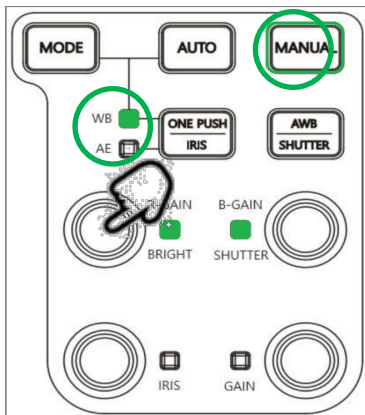

6.1.5 WB R Gain (-50 ~ 50)

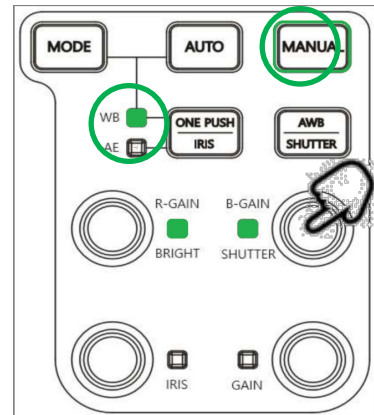

6.1.6 WB B Gain (-50 ~ 50)

Auto Exposure Setting

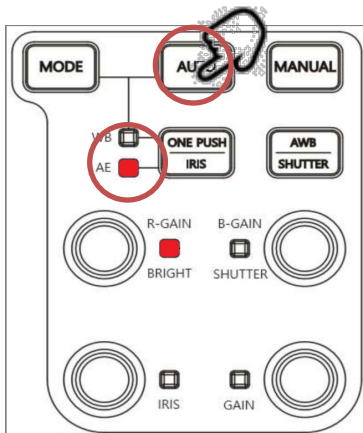

6.1.7 AE Auto

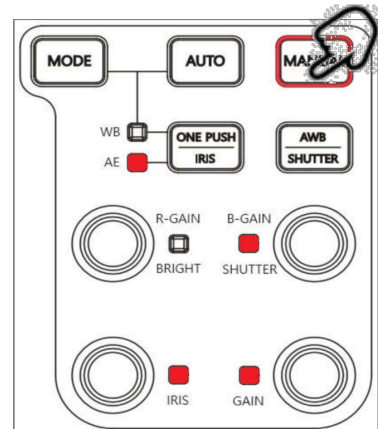

6.1.8 AE Manual

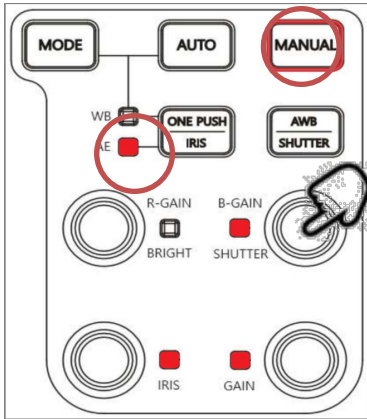

**6.1.5 AE Shutter Speed
Up/Down**

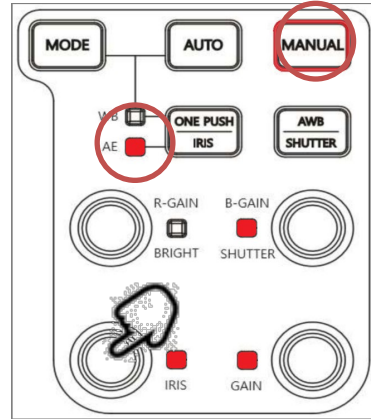

6.1.6 AE IRIS Up/Down

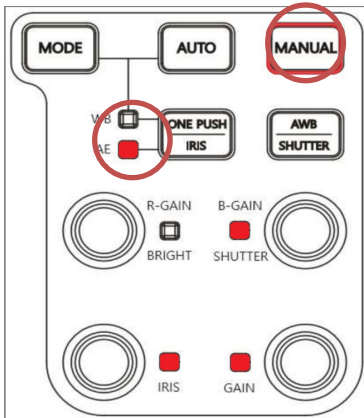

6.1.7 AE Gain Up/Down

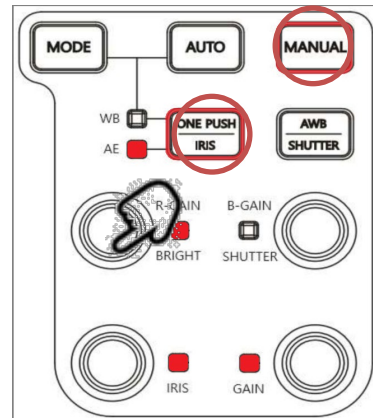

6.1.8 AE B Right Up/Down

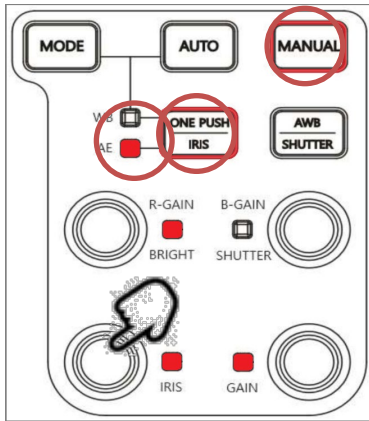

6.1.5 AE IRIS Up/Down

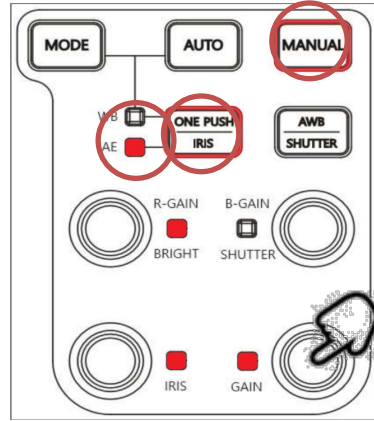

6.1.6 AE Gain Limit Up/Down

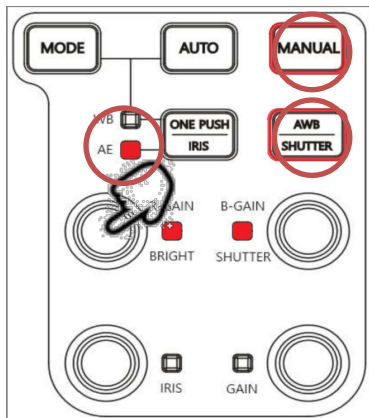

6.1.7 AE B Right Up/Down

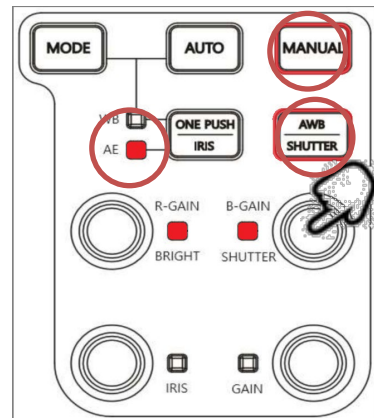

6.1.8 AE Shutter Speed Up/Down

7.1 CAMERA Remote Connectivity and HDMI workflow

- You should make sure that 2.5 mm LANC terminal is on the camera
- It must not exceed 3.2Kg (7 lb) including the lens, all accessory.
- To operate the ZOOM remotely, the motorized zoom (electric) must be installed on the camera.
- Auto or Manual is not converted thru LANC, but the Camera must be manually select in advance to able to remotely support Focus and Iris



SONY a 7 / FX7



Panasonic BGH1/ SONY/CANON/JVC



Canon XF605



JVC

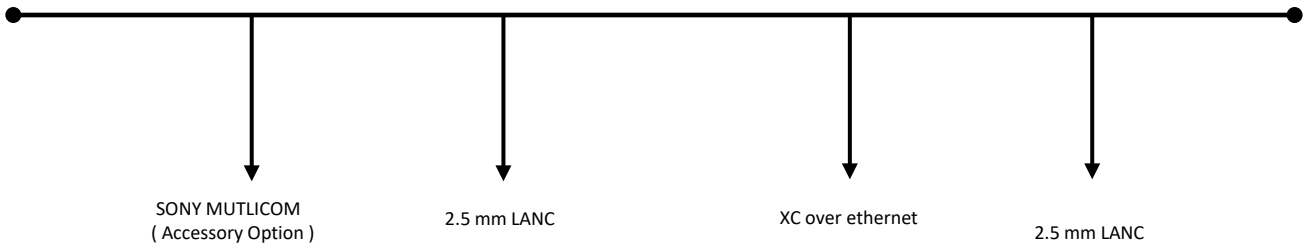

SHARON proSTICK



VSICA IP



HDMI



HDMI Video Switcher

8 VBOT Finder

8-1. VBOT Finder Apps Download

Please visit to SalrayWorks download page as below <http://salrayworks.com/index.php/download/vbot-finder-for-window-pc/> and you can download and install Sharon finder app for both of Window OS version.

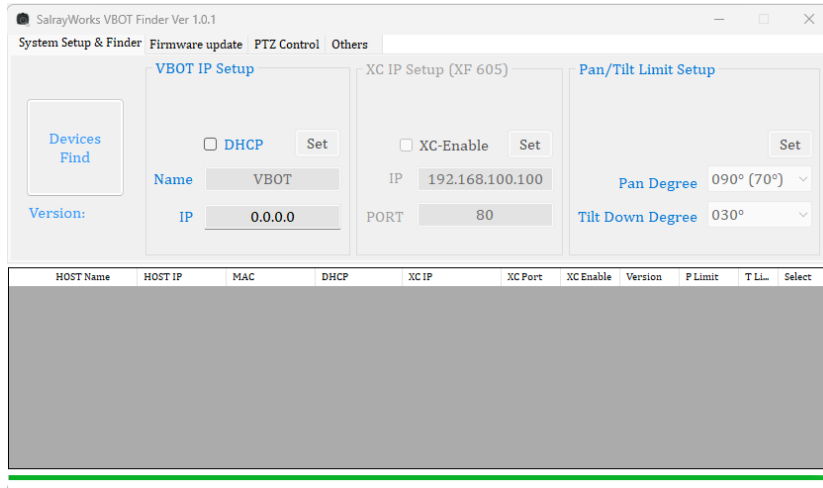

When the installation is complete, the Desktop VBOT Finder Icon will appear on your Desktop



8-2. VBOT Finder GUI

If you click VBOT finder icon, the following window appears, scan all VBOT devices on the same Network and display a list as below. You can update the latest firmware.

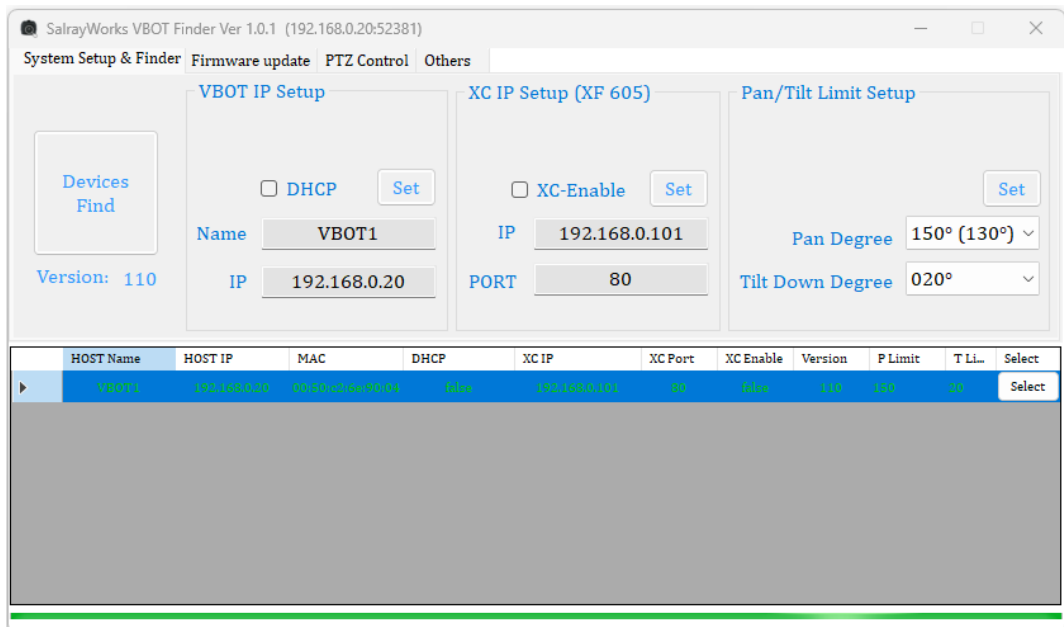

9. SONY Multiport Converter Module Option. (Model : SONY Multi COM)



9-1 The List of Camera Model

Some Sony camera models can be remotely controlled only through the Multi interface Shoe instead of the 2.5 mm LANC terminal. In this case, you must purchase the SONY Multiport Converter Module separately.

Model : SONY FX3, SONY ALPHA 7 IIIe

Remote support for the following function.

- Zoom Tele (SW command)
- Zoom Wide (SW command)
- Recoding Start/Stop (SW command)

- Power On/Off (HW command)
- Sutter (SW command & HW command)

9-2. List of SONY Camera supported by SONY MULTIPOINT Interface shoe

A1	A7RM4A	A7RM3A	A7 IV
A6500	A6400	A6300	A6000
A5100	A5000	A3500	A3000
A7 III	A7 II	A7	A7R III
A7R II	A7R	A7S II	A7S
A9	ILCE-QX1	A7R IV	A6100
A6600	A9 II	A7S III	
A99 II	A77 II	A68	A58
RX100 VII	ZV-1	RX0M2	
RX100 VI	RX100 VA	RX100 V	RX100 IV
RX100 III	RX100 II	RX10 IV	RX10 III
RX10 II	RX10	RX1R II	WX800
WX700	WX500	HX300	HX350
HX400	HX400V	HX50	HX50V
HX60	HX60V	HX80	HX90V
HX95	HX99	QX30	RX0 *
FDR-AX43			
FDR-AX100	FDR-AX100E	FDR-AX30	FDR-AX33
FDR-AX40	FDR-AX45	FDR-AX53	FDR-AX55
FDR-AX60	FDR-AX700	FDR-AXP33	FDR-AXP35
FDR-AXP55	HDR-CX220	HDR-CX220E	HDR-CX230
HDR-CX230E	HDR-CX240	HDR-CX240E	HDR-CX280
HDR-CX280E	HDR-CX290	HDR-CX290E	HDR-CX320
HDR-CX320E	HDR-CX330	HDR-CX330E	HDR-CX380
HDR-CX380E	HDR-CX390	HDR-CX390E	HDR-CX400E
HDR-CX405	HDR-CX410VE	HDR-CX420	HDR-CX430V
HDR-CX430VE	HDR-CX440	HDR-CX450	HDR-CX455
HDR-CX470	HDR-CX480	HDR-CX485	HDR-CX510E
HDR-CX530E	HDR-CX535	HDR-CX610E	HDR-CX620
HDR-CX625	HDR-CX630V	HDR-CX670	HDR-CX675
HDR-CX680	HDR-CX900	HDR-CX900E	HDR-PJ220
HDR-PJ220E	HDR-PJ230	HDR-PJ230E	HDR-PJ240
HDR-PJ240E	HDR-PJ270	HDR-PJ270E	HDR-PJ275
HDR-PJ320E	HDR-PJ330E	HDR-PJ340	HDR-PJ340E
HDR-PJ350	HDR-PJ350E	HDR-PJ380	HDR-PJ380E
HDR-PJ390	HDR-PJ390E	HDR-PJ410	HDR-PJ420E
HDR-PJ420VE	HDR-PJ430	HDR-PJ430E	HDR-PJ430V
HDR-PJ430VE	HDR-PJ440	HDR-PJ510E	HDR-PJ530E
HDR-PJ540	HDR-PJ540E	HDR-PJ610E	HDR-PJ620
HDR-PJ630V	HDR-PJ650E	HDR-PJ650V	HDR-PJ650VE
HDR-PJ660	HDR-PJ660E	HDR-PJ660V	HDR-PJ660VE
HDR-PJ670	HDR-PJ675	HDR-PJ680	HDR-PJ780E
HDR-PJ780VE	HDR-PJ790	HDR-PJ790E	HDR-PJ790V
HDR-PJ790VE	HDR-PJ800	HDR-PJ810	HDR-PJ810E
HDR-PJ820	HDR-PJ820E		

9-3. List of Canon XC Command Key

Command Set [Ⓔ]	Command [Ⓔ]	Command Packet [Ⓔ]	Comments [Ⓔ]	
Inquiry Command [Ⓔ]	Command Packet [Ⓔ]	Inquiry Packet [Ⓔ]	Comments [Ⓔ]	
CAM_VersionInq [Ⓔ]	8x 09 00 02 FF [Ⓔ]	y0 50 00 01 mn pq rs tu vw FF [Ⓔ]	mnpq: Model Code (0x11 0x20) [Ⓔ] rstu: ROM version (0x00 0x01) [Ⓔ] vw: Socket Number (0x01) [Ⓔ]	
CAM_Power [Ⓔ]	On [Ⓔ]	8x 01 04 00 02 FF [Ⓔ]	Power ON/OFF [Ⓔ]	
	Off (Standby) [Ⓔ]	8x 01 04 00 03 FF [Ⓔ]		
CAM_PowerInq [Ⓔ]	8x 09 04 00 FF [Ⓔ]	y0 50 02 FF [Ⓔ]	On [Ⓔ]	
		y0 50 03 FF [Ⓔ]	Off (Standby) - at Visca Only On [Ⓔ]	
CAM_XF605_Zoom XF605 [Ⓔ]	XF605 Direct [Ⓔ]	8x 11 04 47 4z 0p 0q 0r 0s FF [Ⓔ]	ZOOM LOCATION PRECISE CONTROL at XF605 Only On [Ⓔ] z: 1 (Slow) to 7 (Fast) [Ⓔ] pqrs: Zoom Position (MIN <u>530</u> , MAX 7300) [Ⓔ]	
CAM_XF605_ZoomInq XF605 [Ⓔ]	8x 29 04 47 FF [Ⓔ]	y0 50 0p 0q 0r 0s FF [Ⓔ]	pqrs: See the VBOT Command Setting Values (ZOOM) section [Ⓔ]	
CAM_XF605_Focus XF605 [Ⓔ]	XF605 Direct [Ⓔ]	8x 01 04 48 0p 0q 0r 0s FF [Ⓔ]	Direct XF605 (<u>80~2000</u>) at XF605 Only On [Ⓔ]	
CAM_XF605_FocusInq XF605 [Ⓔ]	8x 29 04 48 FF [Ⓔ]	y0 50 0p 0q 0r 0s FF [Ⓔ]	pqrs: See the VBOT Command Setting Values (FOCUS) section [Ⓔ]	
CAM_Zoom XF605 [Ⓔ]	VISCA Direct [Ⓔ]	8x 11 04 47 2p 0p 0q 0r 0s FF [Ⓔ]	p: 1 (Slow) to 7 (Fast) [Ⓔ] pqrs: Zoom Position (MIN 0x0000, MAX 0x4000) [Ⓔ]	
CAM_ZoomInq XF605 [Ⓔ]	8x 09 04 47 FF [Ⓔ]	y0 50 0p 0q 0r 0s FF [Ⓔ]	pqrs: See the VISCA Command Setting Values (Zoom) section [Ⓔ]	
CAM_Focus XF605 [Ⓔ]	VISCA Direct [Ⓔ]	8x 01 04 48 0p 0q 0r 0s FF [Ⓔ]	pqrs: See the VISCA Command Setting Values (FOCUS) section (Min <u>0x1000</u> Max <u>0xC000</u>) at XF605 Only On [Ⓔ]	
CAM_FocusInq XF605 [Ⓔ]	8x 09 04 48 FF [Ⓔ]	y0 50 0p 0q 0r 0s FF [Ⓔ]	pqrs: See the VISCA Command Setting Values (FOCUS) section [Ⓔ]	
CAM_Zoom [Ⓔ]	Stop [Ⓔ]	8x 01 04 07 00 FF [Ⓔ]	Zoom Control [Ⓔ]	
	Tele (Standard) [Ⓔ]	8x 01 04 07 02 FF [Ⓔ]		
	Wide (Standard) [Ⓔ]	8x 01 04 07 03 FF [Ⓔ]		
	Tele (Variable) [Ⓔ]	8x 01 04 07 2p FF [Ⓔ]		
	Wide (Variable) [Ⓔ]	8x 01 04 07 3p FF [Ⓔ]		
CAM_Focus [Ⓔ]	Stop [Ⓔ]	8x 01 04 08 00 FF [Ⓔ]	p=1 (Low) to 7 (High) [Ⓔ]	
	Far (Standard) [Ⓔ]	8x 01 04 08 02 FF [Ⓔ]		
	Near (Standard) [Ⓔ]	8x 01 04 08 03 FF [Ⓔ]		
	Far (Variable) [Ⓔ]	8x 01 04 08 2p FF [Ⓔ]		
	Near (Variable) [Ⓔ]	8x 01 04 08 3p FF [Ⓔ]		
	Auto Focus [Ⓔ]	8x 01 04 38 02 FF [Ⓔ]		AF ON/OFF Toggle [Ⓔ]
	Manual Focus [Ⓔ]	8x 01 04 38 03 FF [Ⓔ]		pqrs: See the VISCA Command Setting Values (FOCUS) section [Ⓔ]
	Auto/Manual [Ⓔ]	8x 01 04 38 10 FF [Ⓔ]		VISCA (0x2000 ~0xC000) [Ⓔ]
EXPOSURE MODE [Ⓔ]	Full Auto [Ⓔ]	8x 01 04 39 00 FF [Ⓔ]	IRIS=auto, Shutter =auto, Gain=auto [Ⓔ]	
	Manual [Ⓔ]	8x 01 04 39 03 FF [Ⓔ]	[Ⓔ]	
EXPOSURE AE Level [Ⓔ] XF605 [Ⓔ]	Up [Ⓔ]	8x 01 04 0E 02 FF [Ⓔ]	pq: See the VISCA Command Setting Values (AE Level) <u>0x00~0x10</u> [Ⓔ]	
	Down [Ⓔ]	8x 01 04 0E 03 FF [Ⓔ]		
	Direct [Ⓔ]	8x 01 04 4E 00 00 0p 0q FF [Ⓔ]		
CAM_AE_LevelInq_XF605 [Ⓔ]	8x 09 04 4E FF [Ⓔ]	y0 50 00 00 00 0p FF [Ⓔ]	p: See the VISCA Command Setting Values (AE Level) section [Ⓔ]	
EXPOSURE IRIS [Ⓔ] XF605 [Ⓔ]	Up (OPEN) [Ⓔ]	8x 01 04 0B 02 FF [Ⓔ]	Iris Setting [Ⓔ] <u>Up(-1), Down(+1)</u> [Ⓔ] pq: See the VISCA Command Setting Values (IRIS) section [Ⓔ]	
	Down (CLOSE) [Ⓔ]	8x 01 04 0B 03 FF [Ⓔ]		
	Direct [Ⓔ]	8x 01 04 4B 00 00 0p 0q FF [Ⓔ]		
CAM_AE IRISInq F605 [Ⓔ]	8x 09 04 4B FF [Ⓔ]	y0 50 00 00 0p 0q FF [Ⓔ]	pq: See the VISCA Command Setting Values (IRIS) section [Ⓔ]	

Command Set ^㉔	Command ^㉔	Command Packet ^㉔	Comments ^㉔
Inquiry Command ^㉔	Command Packet ^㉔	Inquiry Packet ^㉔	Comments ^㉔
EXPOSUREShutter XF605 ^㉔	Up ^㉔	8x 01 04 0A 02 FF ^㉔	pq: See the VISCA Command Setting Values (SHUTTER) section ^㉔
	Down ^㉔	8x 01 04 0A 03 FF ^㉔	
	Direct ^㉔	8x 01 04 4A 00 00 0p 0q FF ^㉔	
CAM_AE SHUTTERInq XF605 ^㉔	8x 09 04 4A FF ^㉔	y0 50 00 00 0p 0q FF ^㉔	
EXPOSURE ^㉔ Gain ^㉔ XF605 ^㉔	Up ^㉔	8x 01 04 0C 02 FF ^㉔	pq: See the VISCA Command Setting Values (GAIN) section ^㉔
	Down ^㉔	8x 01 04 0C 03 FF ^㉔	
	Direct ^㉔	8x 01 04 4C 00 00 0p 0q FF ^㉔	
CAM_Preset ^㉔	Reset ^㉔	8x 01 04 3F 00 0p FF ^㉔	p: preset 0 ~ 9 ^㉔
	Set ^㉔	8x 01 04 3F 01 0p FF ^㉔	q: Speed (0 ~ 23) ^㉔
	Recall ^㉔	8x 01 04 3F 02 0p FF ^㉔	
	Speed ^㉔	8x 01 7E 01 0B 0p qr FF ^㉔	
WB ^㉔ RGAIN ^㉔ XF605 ^㉔	Up ^㉔	8x 01 04 03 02 FF ^㉔	pq: See the VISCA Command Setting Values (AE Level) -50~50 ^㉔ 0~100 XF605 1.0.3.1 No support(확인필요) ^㉔
	Down ^㉔	8x 01 04 03 03 FF ^㉔	
	Direct ^㉔	8x 01 04 44 00 00 0p 0q FF ^㉔	
CAM_WB RGAINInq ^㉔	8x 09 04 43 FF ^㉔	y0 50 00 00 0p 0q FF ^㉔	pq: See the VISCA Command Setting Values (RGAIN) section ^㉔
WB ^㉔ BGAIN ^㉔ XF605 ^㉔	Up ^㉔	8x 01 04 04 02 FF ^㉔	pq: See the VISCA Command Setting Values (B Gain) -50~50 ^㉔ 0~100 XF605 1.0.3.1 No support(확인필요) ^㉔
	Down ^㉔	8x 01 04 04 03 FF ^㉔	
	Direct ^㉔	8x 01 04 44 00 00 0p 0q FF ^㉔	
CAM_WB BGAINInq ^㉔	8x 09 04 44 FF ^㉔	y0 50 00 00 0p 0q FF ^㉔	pq: See the VISCA Command Setting Values (BGAIN) section ^㉔
WB MANUAL XF605 ^㉔	AUTO ^㉔	8x 01 04 35 00 FF ^㉔	
	One Push WB Trigger ^㉔	8x 01 04 10 05 FF ^㉔	
	kelvin ^㉔	8x 01 04 35 01 FF ^㉔	3510K ^㉔
	daylight ^㉔	8x 01 04 35 02 FF ^㉔	5600K ^㉔
	tungsten ^㉔	8x 01 04 35 03 FF ^㉔	3200K ^㉔
	wb_a ^㉔	8x 01 04 35 04 FF ^㉔	5600K ^㉔
	wb_b ^㉔	8x 01 04 35 05 FF ^㉔	5600k ^㉔
	Up ^㉔	8x 01 04 35 06 FF ^㉔	WB kelvin Setting ^㉔ Up(-1), Down(+1) ^㉔ pq: See the VISCA Command Setting Values (WB_) section ^㉔
	Down ^㉔	8x 01 04 35 07 FF ^㉔	
Direct ^㉔	8x 01 04 35 08 00 0p 0q FF ^㉔		
CAM_WB GAINInq ^㉔	8x 09 04 45 FF ^㉔	y0 50 00 00 0p 0q FF ^㉔	pq: See the VISCA Command Setting Values (GAIN) section ^㉔

Command Set [Ⓔ]	Command [Ⓔ]	Command Packet [Ⓔ]	Comments [Ⓔ]
Inquiry Command [Ⓔ]	Command Packet [Ⓔ]	Inquiry Packet [Ⓔ]	Comments [Ⓔ]
CAM Info Display [Ⓔ]	On/Off [Ⓔ]	8x 01 06 06 10 FF [Ⓔ]	Turn On/Off Info screen [Ⓔ]
Pan_tiltDrive [Ⓔ]	Up [Ⓔ]	8x 01 06 01 VV WW 03 01 FF [Ⓔ]	VV: Pan speed 0x01 to 0x18 (00: Stop) [Ⓔ] WW: Tilt Speed 0x01 to 0x17, (00: Stop) [Ⓔ] YYY: Pan Position [Ⓔ] ZZZ: Tilt Position (center 0000) [Ⓔ] Refer to the section of the Pan/Tilt Position (for reference) of VISCA Command Setting Values. [Ⓔ]
	Down [Ⓔ]	8x 01 06 01 VV WW 03 02 FF [Ⓔ]	
	Left [Ⓔ]	8x 01 06 01 VV WW 01 03 FF [Ⓔ]	
	Right [Ⓔ]	8x 01 06 01 VV WW 02 03 FF [Ⓔ]	
	UpLeft [Ⓔ]	8x 01 06 01 VV WW 01 01 FF [Ⓔ]	
	UpRight [Ⓔ]	8x 01 06 01 VV WW 02 01 FF [Ⓔ]	
	DownLeft [Ⓔ]	8x 01 06 01 VV WW 01 02 FF [Ⓔ]	
	DownRight [Ⓔ]	8x 01 06 01 VV WW 02 02 FF [Ⓔ]	
	Stop [Ⓔ]	8x 01 06 01 VV WW 03 03 FF [Ⓔ]	
	AbsolutePosition [Ⓔ]	8x 01 06 02 VV WW 0Y 0Y 0Y 0Z 0Z 0Z FF [Ⓔ]	
	RelativePosition [Ⓔ]	8x 01 06 03 VV WW 0Y 0Y 0Y 0Z 0Z 0Z FF [Ⓔ]	
Home [Ⓔ]	8x 01 06 04 FF [Ⓔ]		
Pan_tiltPosInq [Ⓔ]	8x 09 06 12 FF [Ⓔ]	y0 50 0w 0w 0w 0z 0z 0z FF [Ⓔ]	www = Pan Position [Ⓔ] zzz = Tilt Position [Ⓔ]

Command Set [Ⓔ]	Command [Ⓔ]	Command Packet [Ⓔ]	Comments [Ⓔ]
Inquiry Command [Ⓔ]	Command Packet [Ⓔ]	Inquiry Packet [Ⓔ]	Comments [Ⓔ]
CAM_TallyLamp [Ⓔ]	On/Off [Ⓔ]	8x 01 7E 01 0A 00 0p FF [Ⓔ]	p: 2h=On, 3h=Off [Ⓔ]
CAM_TallyLampInq [Ⓔ]	8x 09 7E 01 0A FF [Ⓔ]	y0 50 02 FF [Ⓔ]	On [Ⓔ]
		y0 50 03 FF [Ⓔ]	Off [Ⓔ]

Pan[Ⓔ]

Angle (degrees) [Ⓔ]	Left [Ⓔ]	Right [Ⓔ]
	YYYY values [Ⓔ]	YYYY values [Ⓔ]
0 [Ⓔ]	0000 [Ⓔ]	0000 [Ⓔ]
10 [Ⓔ]	014D [Ⓔ]	FEB3 [Ⓔ]
20 [Ⓔ]	029A [Ⓔ]	FD66 [Ⓔ]
30 [Ⓔ]	03E7 [Ⓔ]	FC19 [Ⓔ]
40 [Ⓔ]	0535 [Ⓔ]	FACB [Ⓔ]
50 [Ⓔ]	0682 [Ⓔ]	F97E [Ⓔ]
60 [Ⓔ]	07CF [Ⓔ]	F831 [Ⓔ]
70 [Ⓔ]	091D [Ⓔ]	F6E3 [Ⓔ]
80 [Ⓔ]	0A6A [Ⓔ]	F596 [Ⓔ]
90 [Ⓔ]	0BB7 [Ⓔ]	F449 [Ⓔ]
100 [Ⓔ]	0D05 [Ⓔ]	F2FB [Ⓔ]
110 [Ⓔ]	0E52 [Ⓔ]	F1AE [Ⓔ]
120 [Ⓔ]	0F9F [Ⓔ]	F061 [Ⓔ]
130 [Ⓔ]	10ED [Ⓔ]	EF13 [Ⓔ]
140 [Ⓔ]	123A [Ⓔ]	EDC6 [Ⓔ]
150 [Ⓔ]	1387 [Ⓔ]	EC79 [Ⓔ]
160 [Ⓔ]	14D5 [Ⓔ]	EB2B [Ⓔ]
170 [Ⓔ]	1622 [Ⓔ]	E9DE [Ⓔ]

Tilt[Ⓔ]

Angle (degrees) [Ⓔ]	Up [Ⓔ]	Down [Ⓔ]
	ZZZZ values [Ⓔ]	ZZZZ values [Ⓔ]
0 [Ⓔ]	0000 [Ⓔ]	0000 [Ⓔ]
5 [Ⓔ]	00A6 [Ⓔ]	FF5A [Ⓔ]
10 [Ⓔ]	014D [Ⓔ]	FEB3 [Ⓔ]
15 [Ⓔ]	01F3 [Ⓔ]	FE0D [Ⓔ]
20 [Ⓔ]	029A [Ⓔ]	FD66 [Ⓔ]
25 [Ⓔ]	- [Ⓔ]	FCBF [Ⓔ]
30 [Ⓔ]	- [Ⓔ]	FC19 [Ⓔ]
35 [Ⓔ]	- [Ⓔ]	FB72 [Ⓔ]
40 [Ⓔ]	- [Ⓔ]	FACB [Ⓔ]

[Position Value = (Angle * 8533) >> 8][Ⓔ]

Focus Position (for reference) for VISCA Command Setting Values



Focus Ratio	Focus Distance	
0x1000	2000	∞
0x2000	1460	14.6m
0x3000	630	6.3m
0x4000	3900	3.9m
0x5000	280	2.8m
0x6000	220	2.2m
0x7000	170	1.7m
0x8000	140	1.4m
0x9000	120	1.2m
0xA000	100	1.0m
0xB000	90	0.9m
0xC000	80	0.8m
2000	2000	∞
1800	1800	1.8m
....
90	90	0.9m
80	80	0.8m

AE Shutter Position (for reference) for VISCA Command Setting Value

AE Shutter	AE Shutter Distance	
0x06	60	1/60
0x07	75	1/75
0x08	90	1/90
0x09	100	1/100
0x0A	120	1/120
0x0B	150	1/150
0x0C	180	1/180
0x0D	210	1/210
0x0E	250	1/250
0x0F	300	1/300
0x10	360	1/360
0x11	420	1/420
0x12	500	1/500
0x13	600	1/600
0x14	720	1/720
0x15	840	1/840
0x16	1000	1/1000
0x17	1200	1/1200
0x18	1400	1/1400
0x19	1700	1/1700
0x1A	2000	1/2000



AE Gain Position (for reference) for VISCA Command Setting Value



GAIN RATIO		GAIN DISTANCE	
0	-60	-6dB	
1	-30	-3dB	
2	0	0dB	
3	30	3dB	
4	60	6dB	
5	90	9dB	
6	120	12dB	
7	150	15dB	
8	180	18dB	
9	210	21dB	

AE IRIS Position (for reference) for VISCA Command Setting Value

AE IRIS Ratio	IRIS Distance		
0x00	2000	F20	
0x01	1600	F16	
0x02	1500	F15	
0x03	1300	F13	
0x04	1200	F12	
0x05	1100	F11	XF605 Max
0x06	1000	F10	
0x07	950	F9.5	
0x08	870	F8.7	
0x09	800	F8.0	
0x0A	730	F7.3	
0x0B	670	F6.7	
0x0C	620	F6.2	
0x0D	560	F5.6	
0x0E	520	F5.2	
0x0F	480	F4.8	
0x10	440	F4.4	XF605 Min
0x11	400	F4.0	
0x12	370	F3.7	
0x13	340	F3.4	
0x14	310	F3.1	
0x15	280	F2.8	
0x16	260	F2.6	
0x17	240	F2.4	
0x18	220	F2.2	
0x19	190	F1.9	



AE Level Position (for reference) for VISCA Command Setting Values



AE Level Ratio	AE Level Distance	
0	-8	-2
1	-7	-1.75
2	-6	-1.5
3	-5	-1.25
4	-4	-1
5	-3	-0.75
6	-2	-0.5
7	-1	-0.25
8	0	0
9	1	0.25
10	2	0.5
11	3	0.75
12	4	1
13	5	1.25
14	6	1.5
15	7	1.75
16	8	2

WB Rgain/Bgain (for reference)for VISCA Command Setting Values

WB gain Ratio	WB gain Distance
0	-50
1	-49
2	-48
...	...
50	0
51	1
...	...
99	49
100	50



WB Kelvin Position (for reference)for VISCA Command Setting Values



WB kelvin Ratio	WB kelvin Distance	
0	2000	
1	2020	
2	2040	
...	...	
50	4000	
51	4080	
...	...	
86	14290	
87	15000	

V BOT VISCA IP Commands

Execution and Inquiry Command List

Command Set	Command	Command Packet	Comments	
Inquiry Command	Command Packet	Inquiry Packet	Comments	
CAM_VersionInq	8x 09 00 02 FF	y0 50 00 01 mn pq rs tu vw FF	mnpq: Model Code (0x11 0x20) rstu: ROM version (0x00 0x01) vw: Socket Number (0x01)	
CAM_Power	On	8x 01 04 00 02 FF	Power ON/OFF	
	Off (Standby)	8x 01 04 00 03 FF		
CAM_PowerInq		y0 50 02 FF	On	
		y0 50 03 FF	Off (Standby) - at Visca Only On	
CAM_XF605_Zoom XF605	XF605 Direct	8x 11 04 47 4z 0p 0q 0r 0s FF	ZOOM LOCATION PRECISE CONTROL at XF605 Only On z: 1 (Slow) to 7 (Fast) pqrs: Zoom Position (MIN 530,MAX 7300)	
CAM_XF605_ZoomInq XF605	8x 29 04 47 FF	y0 50 0p 0q 0r 0s FF	pqrs: See the VBOT Command Setting Values (ZOOM) section	
CAM_XF605_Focus XF605	XF605 Direct	8x 01 04 48 0p 0q 0r 0s FF	Direct XF605 (80~2000) at XF605 Only On	
CAM_XF605_FocusInq XF605	8x 29 04 48 FF	y0 50 0p 0q 0r 0s FF	pqrs: See the VBOT Command Setting Values (FOCUS) section	
CAM_Zoom XF605	VISCA Direct	8x 11 04 47 2p 0p 0q 0r 0s FF	p: 1 (Slow) to 7 (Fast) pqrs: Zoom Position (MIN 0x0000, MAX 0x4000)	
CAM_ZoomInq XF605	8x 09 04 47 FF	y0 50 0p 0q 0r 0s FF	pqrs: See the VISCA Command Setting Values (Zoom) section	
CAM_Focus XF605	VISCA Direct	8x 01 04 48 0p 0q 0r 0s FF	pqrs: See the VISCA Command Setting Values (FOCUS) section (Min 0x1000 Max0xC000) at XF605 Only On	
CAM_FocusInq XF605	8x 09 04 48 FF	y0 50 0p 0q 0r 0s FF	pqrs: See the VISCA Command Setting Values (FOCUS) section	
CAM_Zoom	Stop	8x 01 04 07 00 FF	Zoom Control	
	Tele (Standard)	8x 01 04 07 02 FF		
	Wide (Standard)	8x 01 04 07 03 FF		
	Tele (Variable)	8x 01 04 07 2p FF		
	Wide (Variable)	8x 01 04 07 3p FF		
CAM_Focus	Stop	8x 01 04 08 00 FF	p=1 (Low) to 7 (High) (Porstick 0x31/0x21)	
	Far (Standard)	8x 01 04 08 02 FF		
	Near (Standard)	8x 01 04 08 03 FF		
	Far (Variable)	8x 01 04 08 2p FF		
	Near (Variable)	8x 01 04 08 3p FF		
	Auto Focus	8x 01 04 38 02 FF		AF ON/OFF Toggle
	Manual Focus	8x 01 04 38 03 FF		pqrs: See the VISCA Command Setting Values (FOCUS) section
Auto/Manual	8x 01 04 38 10 FF	VISCA (0x2000 ~0xC000)		
EXPOSURE MODE	Full Auto	8x 01 04 39 00 FF	IRIS=auto, Shutter =auto, Gain=auto	
	Manual	8x 01 04 39 03 FF		
EXPOSURE AE Level XF605	Up	8x 01 04 0E 02 FF	pq: See the VISCA Command Setting Values (AE Level) 0x00~0x10	
	Down	8x 01 04 0E 03 FF		
	Direct	8x 01 04 4E 00 00 0p 0q FF		
CAM_AE LevelInq XF605	8x 09 04 4E FF	y0 50 00 00 00 0p FF	p: See the VISCA Command Setting Values (AE Level) section	
EXPOSURE IRIS XF605	Up (OPEN)	8x 01 04 0B 02 FF	Iris Setting Up(-1), Down(+1) pq: See the VISCA Command Setting Values (IRIS) section	
	Down (CLOSE)	8x 01 04 0B 03 FF		
	Direct	8x 01 04 4B 00 00 0p 0q FF		
CAM_AE IRISInq F605	8x 09 04 4B FF	y0 50 00 00 0p 0q FF	pq: See the VISCA Command Setting Values (IRIS) section	

V BOT VISCA IP Commands

Execution and Inquiry Command List

Command Set	Command	Command Packet	Comments
Inquiry Command	Command Packet	Inquiry Packet	Comments
EXPOSUREShutter XF605	Up	8x 01 04 0A 02 FF	pq: See the VISCA Command Setting Values (SHUTTER) section
	Down	8x 01 04 0A 03 FF	
	Direct	8x 01 04 4A 00 00 0p 0q FF	
CAM_AE SHUTTERInq XF605	8x 09 04 4A FF	y0 50 00 00 0p 0q FF	
EXPOSURE Gain XF605	Up	8x 01 04 0C 02 FF	pq: See the VISCA Command Setting Values (GAIN) section
	Down	8x 01 04 0C 03 FF	
	Direct	8x 01 04 4C 00 00 0p 0q FF	
CAM_Preset	Reset	8x 01 04 3F 00 0p FF	p : preset 0 ~ 9
	Set	8x 01 04 3F 01 0p FF	q r : Speed (0 ~23)
	Recall	8x 01 04 3F 02 0p FF	
	Speed	8x 01 7E 01 0B 0p qr FF	
WB RGAIN XF605	Up	8x 01 04 03 02 FF	pq: See the VISCA Command Setting Values (AE Level) - 50~50 0~100XF605 1.0.3.1 No support(확인필요)
	Down	8x 01 04 03 03 FF	
	Direct	8x 01 04 44 00 00 0p 0q FF	
CAM_WB RGAINInq	8x 09 04 43 FF	y0 50 00 00 0p 0q FF	pq: See the VISCA Command Setting Values (R GAIN) section
WB BGAIN XF605	Up	8x 01 04 04 02 FF	pq: See the VISCA Command Setting Values (B Gain - 50~50 0~100XF605 1.0.3.1 No support(확인필요)
	Down	8x 01 04 04 03 FF	
	Direct	8x 01 04 44 00 00 0p 0q FF	
CAM_WB BGAINInq	8x 09 04 44 FF	y0 50 00 00 0p 0q FF	pq: See the VISCA Command Setting Values (B GAIN) section
WB MANUAL XF605	AUTO	8x 01 04 35 00 FF	auto white balance
	One Push (Hold Off)	8x 01 04 35 03 FF	Executes auto white balance
	One Push (Hold On)	8x 01 04 10 05 FF	Stops auto white balance
	kelvin	8x 01 04 35 05 FF	3510K
	kelvin	8x 01 04 35 11 FF	3510K
	daylight	8x 01 04 35 12 FF	5600K
	tungsten	8x 01 04 35 13 FF	3200K
	wb_a	8x 01 04 35 14 FF	5600K
	wb_b	8x 01 04 35 15 FF	5600k
	Up	8x 01 04 35 16 FF	WB kelvin Setting Up(-1), Down(+1) pq: See the VISCA Command Setting Values (WB) section
Down	8x 01 04 35 17 FF		
Direct	8x 01 04 35 08 00 0p 0q FF		
CAM_WB GAINInq	8x 09 04 45 FF	y0 50 00 00 0p 0q FF	pq: See the VISCA Command Setting Values (GAIN) section

V BOT VISCA IP Commands

Execution and Inquiry Command List

Command Set	Command	Command Packet	Comments
Inquiry Command	Command Packet	Inquiry Packet	Comments
CAM Info Display	On/Off	8x 01 06 06 10 FF	Turn On/Off Info screen
Pan_tiltDrive	Up	8x 01 06 01 VV WW 03 01 FF	VV: Pan speed 0x01 to 0x18 (00: Stop) WW: Tilt Speed 0x01 to 0x17, (00: Stop) YYYY: Pan Position ZZZZ: Tilt Position (center 0000) Refer to the section of the Pan/Tilt Position (for reference) of VISCA Command Setting Values.
	Down	8x 01 06 01 VV WW 03 02 FF	
	Left	8x 01 06 01 VV WW 01 03 FF	
	Right	8x 01 06 01 VV WW 02 03 FF	
	UpLeft	8x 01 06 01 VV WW 01 01 FF	
	UpRight	8x 01 06 01 VV WW 02 01 FF	
	DownLeft	8x 01 06 01 VV WW 01 02 FF	
	DownRight	8x 01 06 01 VV WW 02 02 FF	
	Stop	8x 01 06 01 VV WW 03 03 FF	
	AbsolutePosition	8x 01 06 02 VV WW 0Y 0Y 0Y 0Y 0Z 0Z 0Z 0Z FF	
	RelativePosition	8x 01 06 03 VV WW 0Y 0Y 0Y 0Y 0Z 0Z 0Z 0Z FF	
Home	8x 01 06 04 FF		
Pan_tiltPosInq	8x 09 06 12 FF	y0 50 0w 0w 0w 0w 0z 0z 0z 0z FF	www = Pan Position zzzz = Tilt Position

Execution and Inquiry Command List

Command Set	Command	Command Packet	Comments
Inquiry Command	Command Packet	Inquiry Packet	Comments
CAM_TallyLamp	On/Off	8x 01 7E 01 0A 00 0p FF	p: 2h=On, 3h=Off
CAM_TallyLampInq	8x 09 7E 01 0A FF	y0 50 02 FF	On
		y0 50 03 FF	Off

Pan/Tilt Position (for reference) for VISCA Command Setting Values

Pan

Angle (degrees)	Left	Right
	YYYY values	YYYY values
0	0000	0000
10	014D	FEB3
20	029A	FD66
30	03E7	FC19
40	0535	FACB
50	0682	F97E
60	07CF	F831
70	091D	F6E3
80	0A6A	F596
90	0BB7	F449
100	0D05	F2FB
110	0E52	F1AE
120	0F9F	F061
130	10ED	EF13
140	123A	EDC6
150	1387	EC79
160	14D5	EB2B
170	1622	E9DE

Tilt

Angle (degrees)	Up	Down
	ZZZZ values	ZZZZ values
0	0000	0000
5	00A6	FF5A
10	014D	FEB3
15	01F3	FE0D
20	029A	FD66
25	-	FCBF
30	-	FC19
35	-	FB72
40	-	FACB

[Position Value = (Angle * 8533) >> 8]

Focus Position (for reference) for VISCA Command Setting Value

XF605

Focus Ratio	Focus Distance	
0x1000	2000	∞
0x2000	1460	14.6m
0x3000	630	6.3m
0x4000	3900	3.9m
0x5000	280	2.8m
0x6000	220	2.2m
0x7000	170	1.7m
0x8000	140	1.4m
0x9000	120	1.2m
0xA000	100	1.0m
0xB000	90	0.9m
0xC000	80	0.8m
2000	2000	∞
1800	1800	1.8m
...
90	90	0.9m
80	80	0.8m

0x1000 이하값이면 Direct

AE Shutter Position (for reference) for VISCA Command Setting Values

XF605

AE Shutter	AE Shutter Distance	
0x00	4	1/4
0x01	8	1/8
0x02	15	1/15
0x03	30	1/30
0x04	34	1/34
0x05	40	1/40
0x06	48	1/48
0x07	50	1/50
0x08	60	1/60
0x09	75	1/75
0x0A	90	1/90
0x0B	100	1/100
0x0C	120	1/120
0x0D	150	1/150
0x0E	180	1/180
0x0F	210	1/210
0x10	250	1/250
0x11	300	1/300
0x12	360	1/360
0x13	420	1/420
0x14	500	1/500
0x15	600	1/600
0x16	720	1/720
0x17	840	1/840
0x18	1000	1/1000
0x19	1200	1/1200
0x1A	1400	1/1400
0x1B	1700	1/1700
0x1C	2000	1/2000

AE Gain Position (for reference) for VISCA Command Setting Values

XF605

Gain Ratio	Gain Distance	
0	-60	-6dB
1	-30	-3dB
2	0	0dB
3	30	3dB
4	60	6dB
5	90	9dB
6	120	12dB
7	150	15dB
8	180	18dB
9	210	21dB

AE GainLimit Position (for reference) for VISCA Command Setting Values

XF605

GainLimit Ratio	Gain Distance	
0x0F	-60	-6dB
0x0E	-30	-3dB
0x0D	0	0dB
0x0C	30	3dB
0x0B	60	6dB
0x0A	90	9dB
0x09	120	12dB
0x08	150	15dB
0x07	180	18dB
0x06	210	21dB

AE IRIS Position (for reference) for VISCA Command Setting Values

XF605

AE IRIS Ratio	IRIS Distance		
0x00	2000	F20	
0x01	1600	F16	
0x02	1500	F15	
0x03	1300	F13	
0x04	1200	F12	
0x05	1100	F11	XF605 Max
0x06	1000	F10	
0x07	950	F9.5	
0x08	870	F8.7	
0x09	800	F8.0	
0x0A	730	F7.3	
0x0B	670	F6.7	
0x0C	620	F6.2	
0x0D	560	F5.6	
0x0E	520	F5.2	
0x0F	480	F4.8	
0x10	440	F4.4	XF605 Min
0x11	400	F4.0	
0x12	370	F3.7	
0x13	340	F3.4	
0x14	310	F3.1	
0x15	280	F2.8	
0x16	260	F2.6	
0x17	240	F2.4	
0x18	220	F2.2	
0x19	190	F1.9	

AE Level Position (for reference) for VISCA Command Setting Values XF605

AE Level Ratio	AE Level Distance	
0	-8	-2
1	-7	-1.75
2	-6	-1.5
3	-5	-1.25
4	-4	-1
5	-3	-0.75
6	-2	-0.5
7	-1	-0.25
8	0	0
9	1	0.25
10	2	0.5
11	3	0.75
12	4	1
13	5	1.25
14	6	1.5
15	7	1.75
16	8	2

WB Rgain/Bgain Position (for reference) for VISCA Command Setting Values XF605

WB gain Ratio	WB gain Distance	
0	-50	
1	-49	
2	-48	
...	...	
50	0	
51	1	
...	...	
99	49	
100	50	

WB kelvin Position (for reference) for VISCA Command Setting Values XF605

WB kelvin Ratio	WB kelvin Distance	
0	2000	
1	2020	
2	2040	
...	...	
50	4000	
51	4080	
...	...	
86	14290	
87	15000	